

Kicad does not allow refs like RxxxA some some devices have been renumbered
 Extra PWR_FLAGS have been added to clear DRC errors
 Some schematic symbols have been eedited to clear DRC errors

Sheet: /PHY & Sundries/
 File: Phy-Sun.kicad_sch

Title: EBAZ4205 Schematic rebuild.

Size: A3	Date: 2021-02-15	Rev: V004
KiCad E.D.A. kicad 5.99.0-unknown-d878cbddbc125ubuntu20.04.1		Id: 2/6

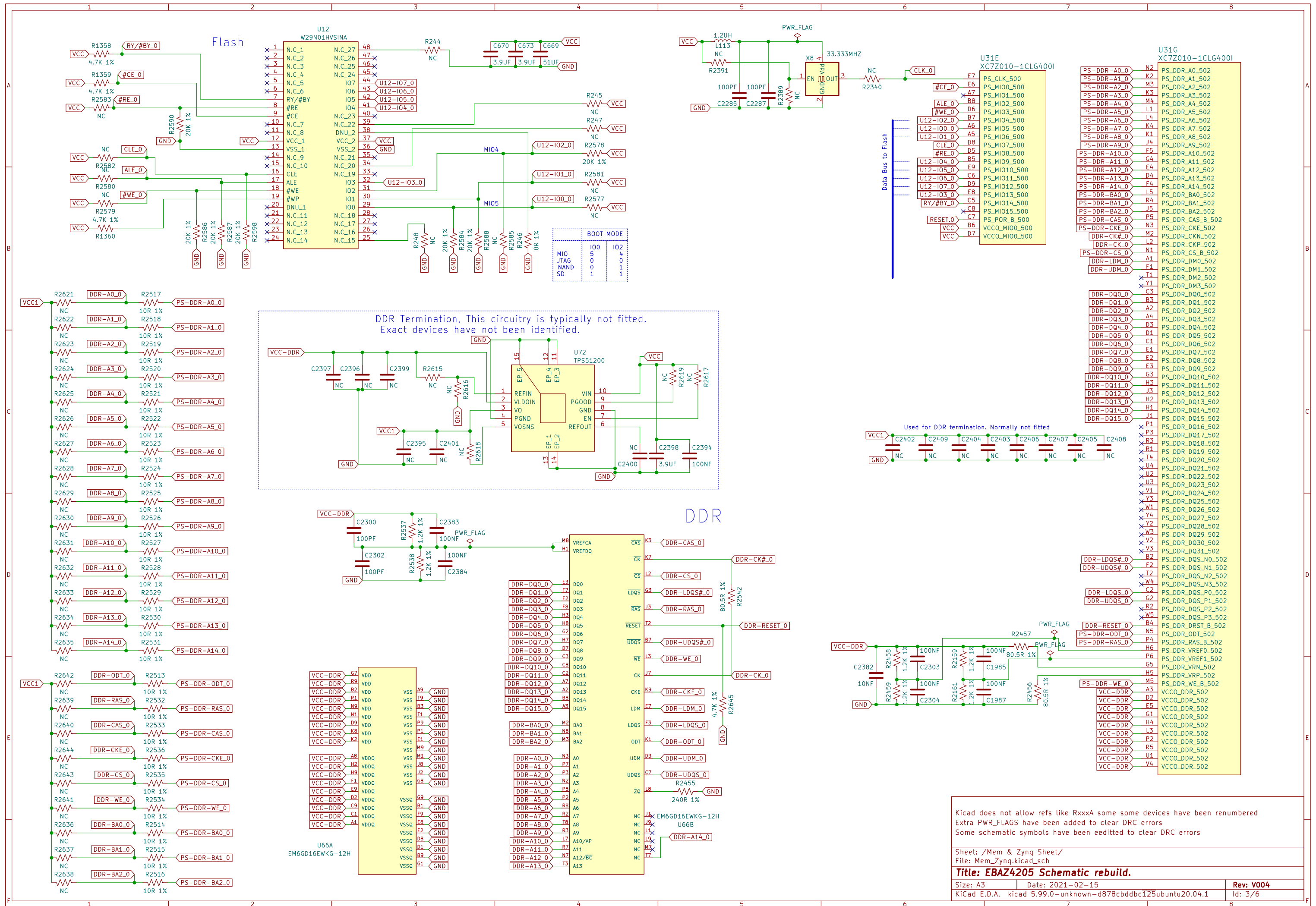

Kicad does not allow refs like RxxxA some some devices have been renumbered
 Extra PWR_FLAGS have been added to clear DRC errors
 Some schematic symbols have been edited to clear DRC errors

Sheet: /Mem & Zynq Sheet/
 File: Mem_Zynq.kicad_sch

Title: EBAZ4205 Schematic rebuild.

Size: A3 Date: 2021-02-15 Rev: V004
 KiCad E.D.A. kicad 5.99.0-unknown-d878cbddbc125ubuntu20.04.1 Id: 3/6

Data Conns

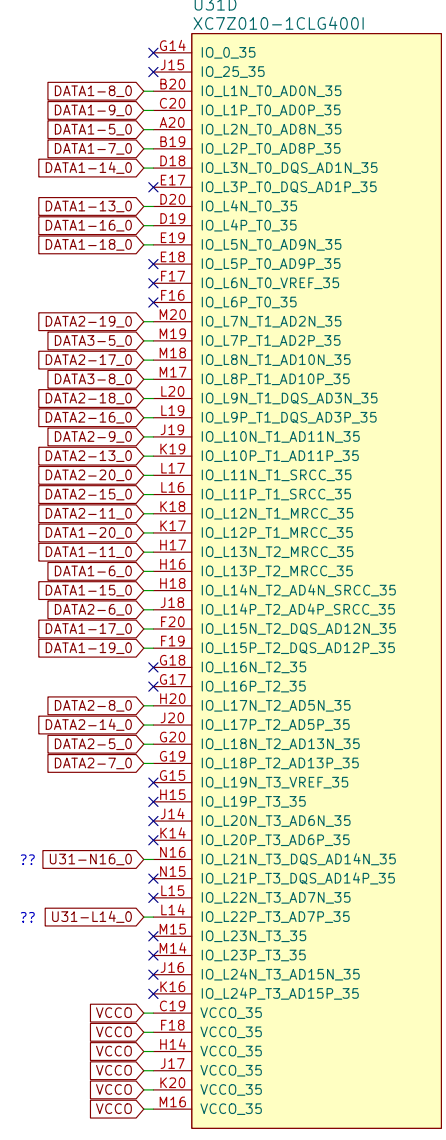
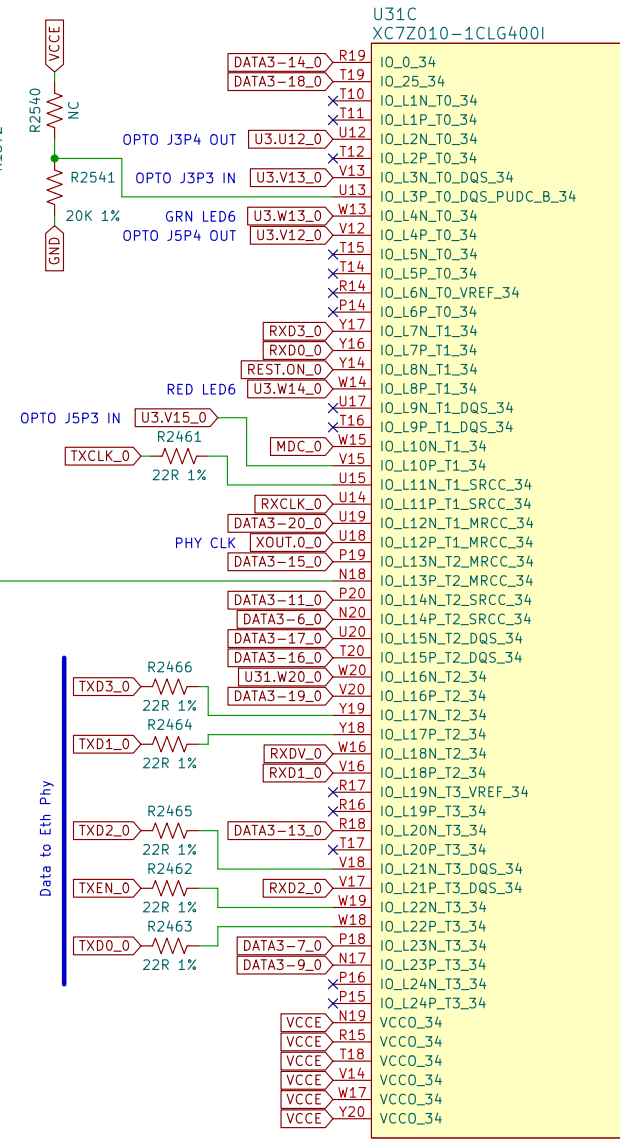
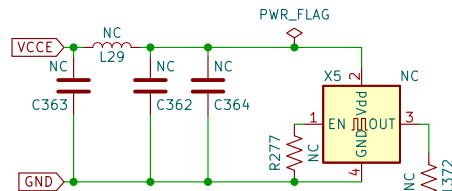
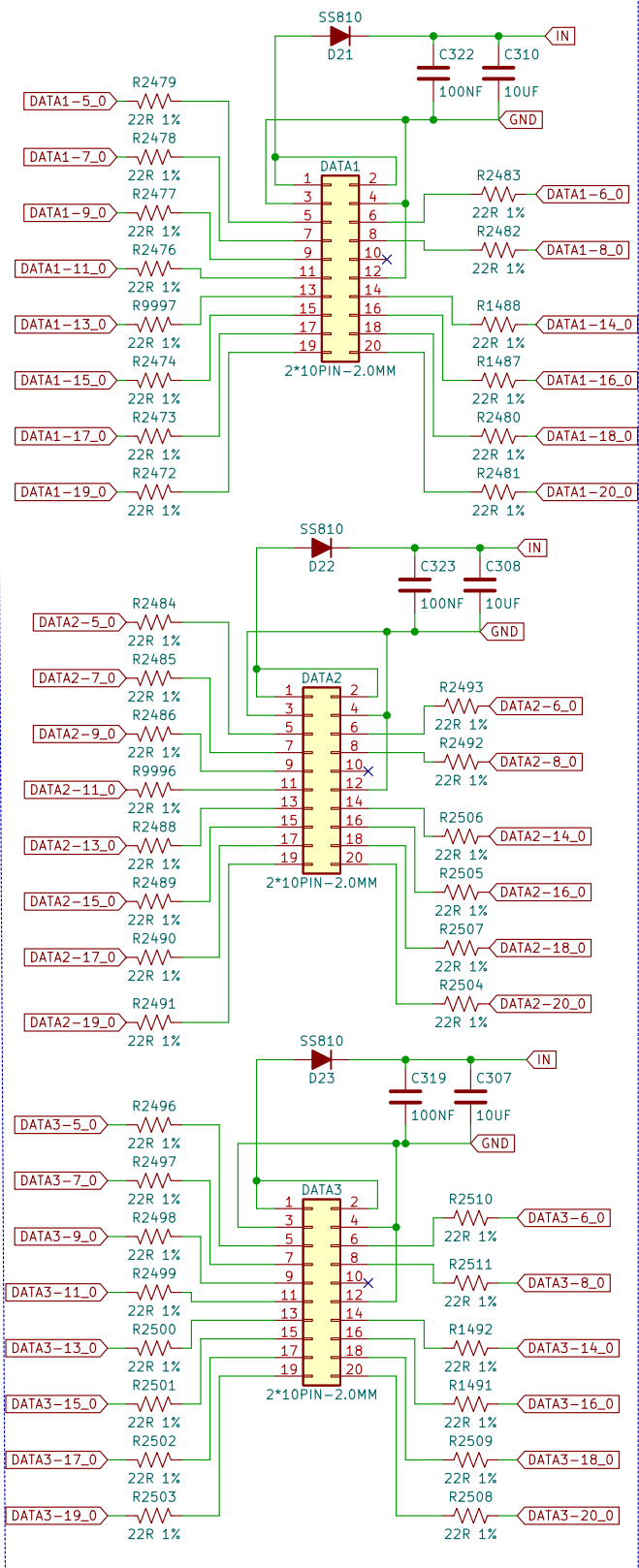

Kicad does not allow refs like RxxxA some some devices have been renumbered
 Extra PWR_FLAGS have been added to clear DRC errors
 Some schematic symbols have been edited to clear DRC errors

Sheet: /Zynq_IO Sheet/
 File: Zynq_IO.kicad_sch

Title: EBAZ4205 Schematic rebuild.

Size: A3	Date: 2021-02-15	Rev: V004
KiCad E.D.A. kicad 5.99.0-unknown-d878cbddbc125ubuntu20.04.1		Id: 4/6

Zynq Power

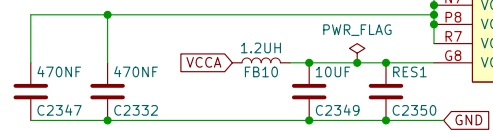
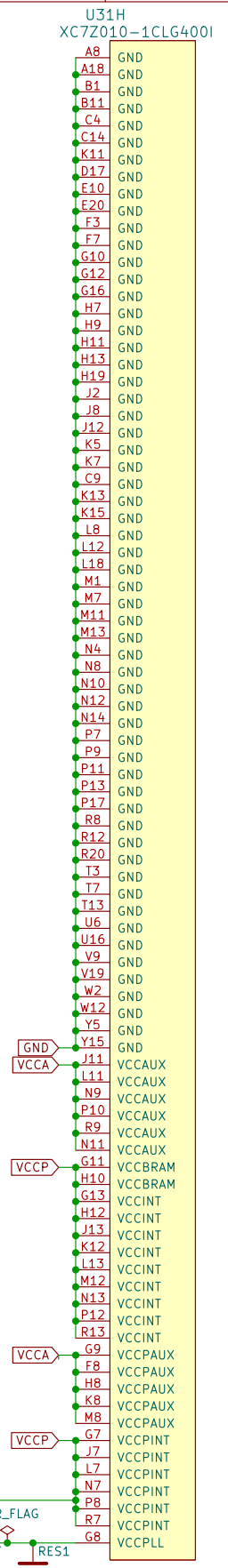
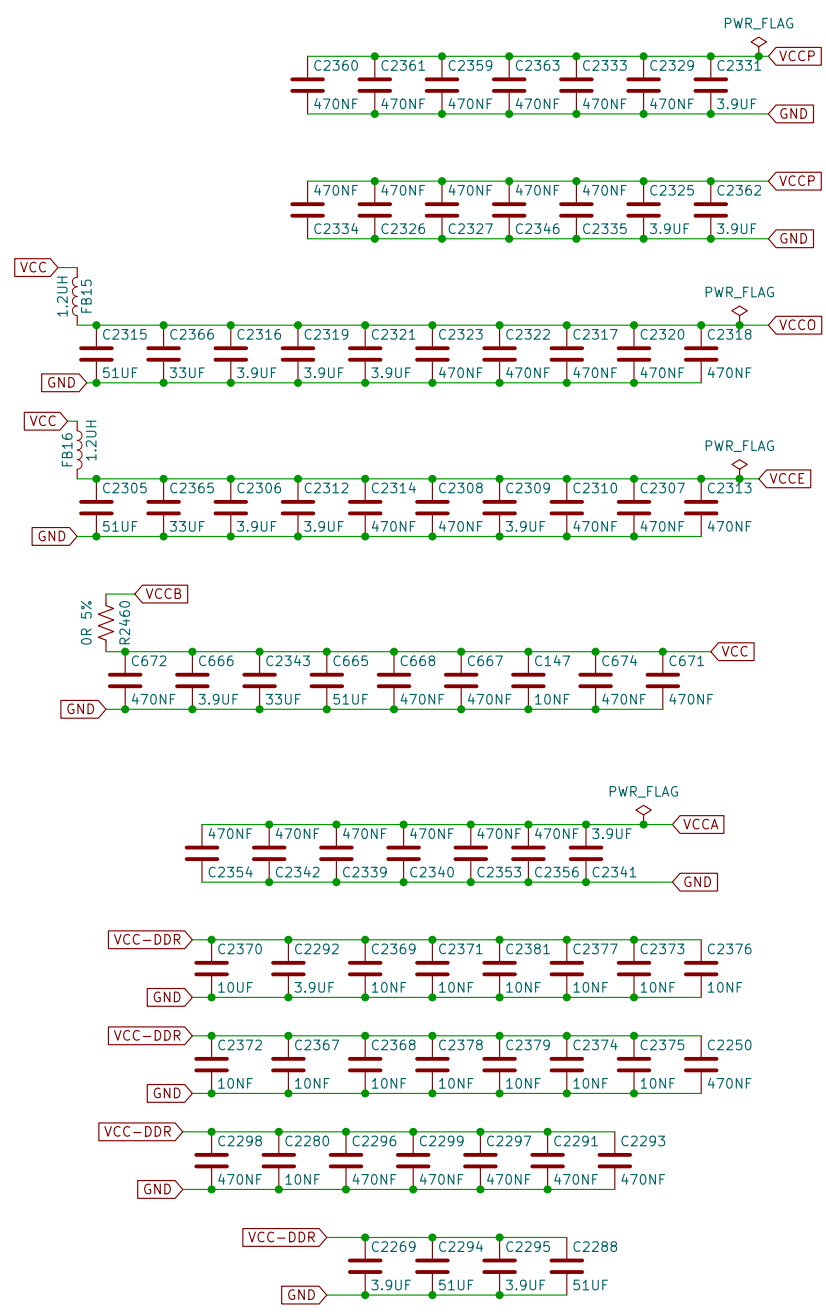
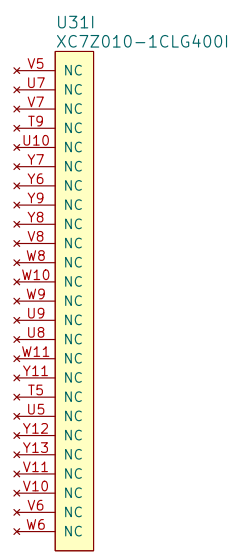
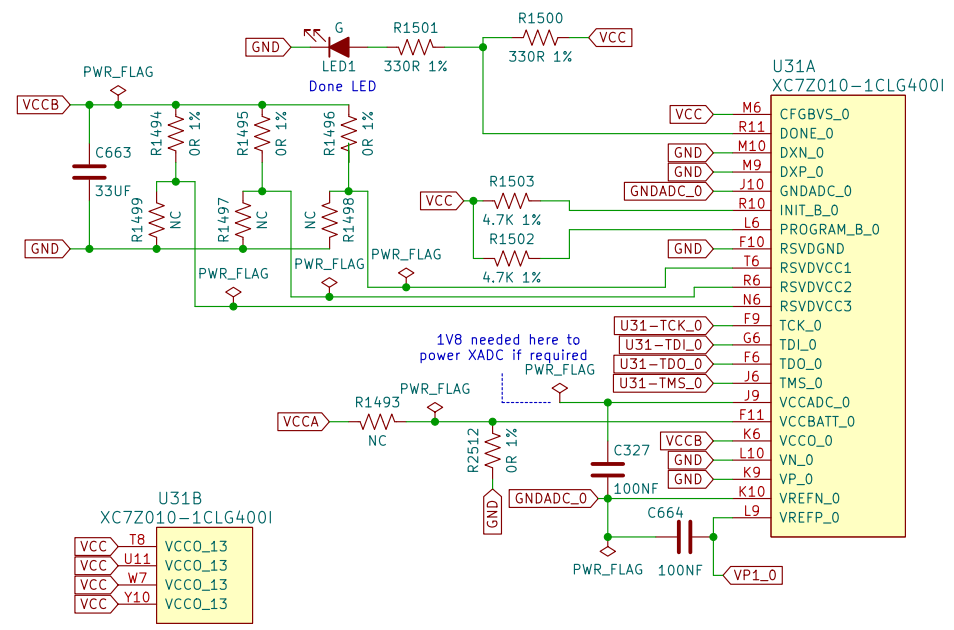

Kicad does not allow refs like RxxxA some some devices have been renumbered
 Extra PWR_FLAGS have been added to clear DRC errors
 Some schematic symbols have been eeditd to clear DRC errors

Sheet: /Zynq Power Sheet/
 File: Zynq_Pwr.kicad_sch

Title: EBAZ4205 Schematic rebuild.

Size: A3	Date: 2021-02-15	Rev: V004
KiCad E.D.A. kicad 5.99.0-unknown-d878cbddbc125ubuntu20.04.1		Id: 5/6

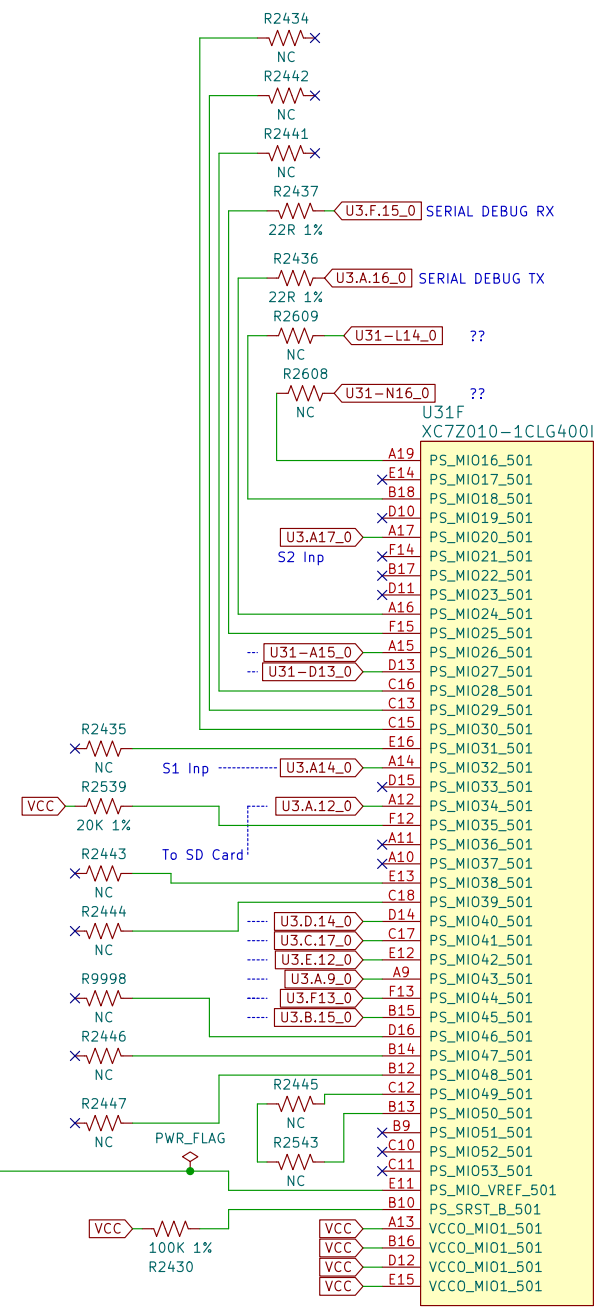
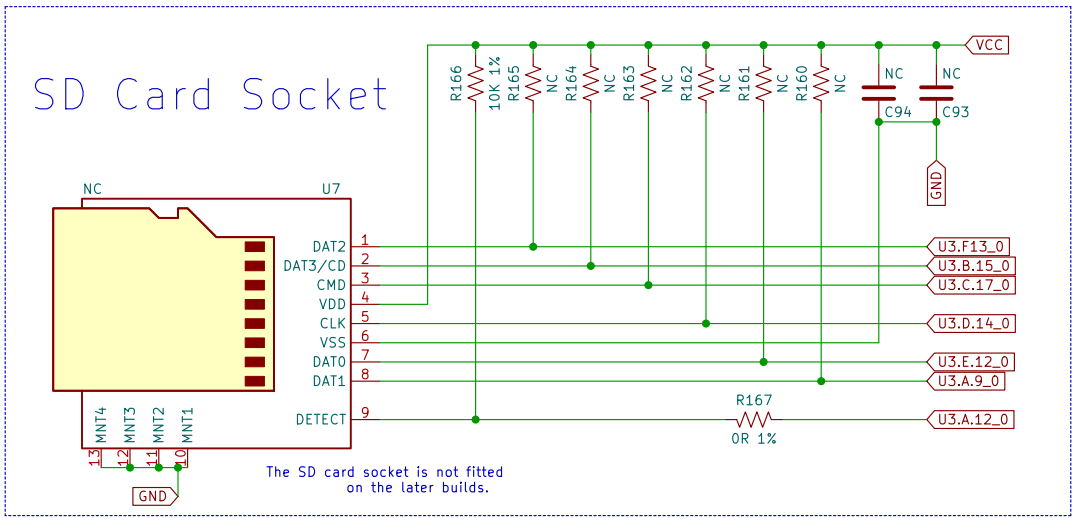
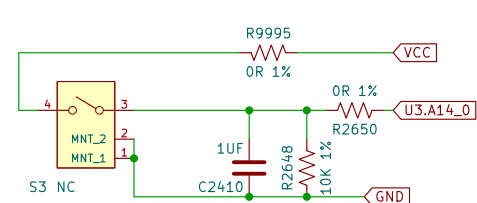
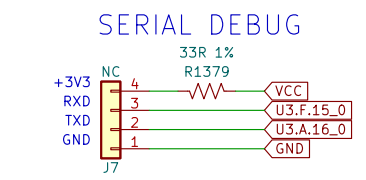
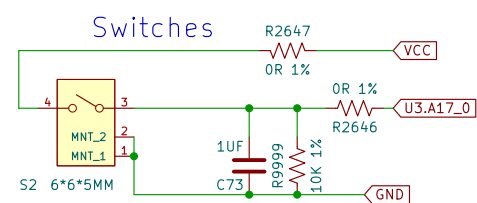
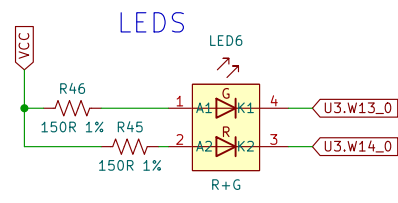

Opto-Isolators

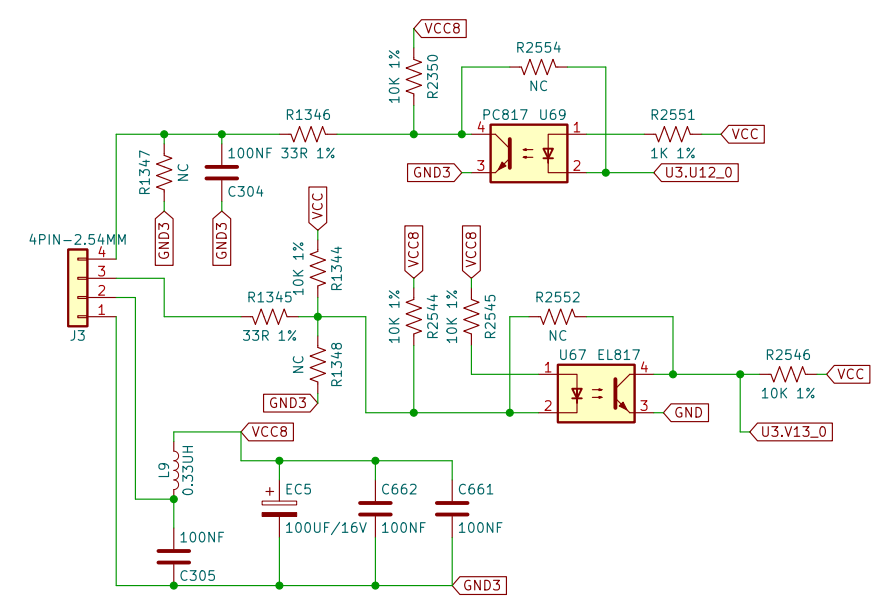

Later build boards do not have the opto devices fitted. In this case the bypass resistors are fitted to allow a single input and output on both J3 and J5

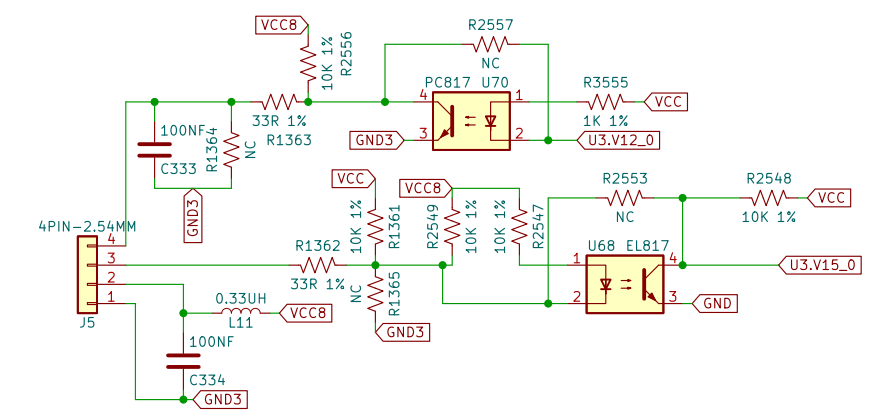

Kicad does not allow refs like RxxxA some some devices have been renumbered
 Extra PWR_FLAGS have been added to clear DRC errors
 Some schematic symbols have been eeditd to clear DRC errors

Power Rails

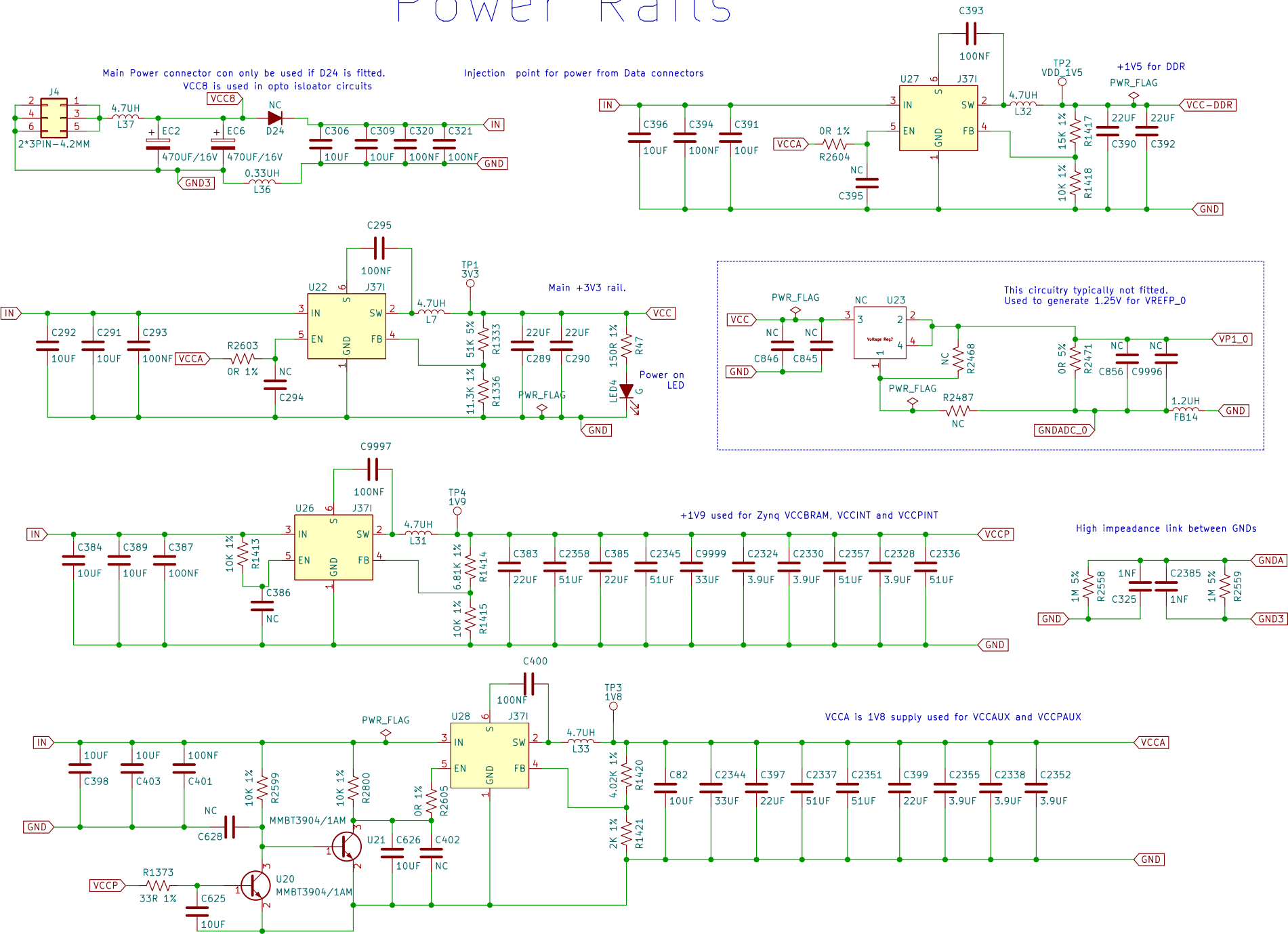

R9999 was R120A
R9998 was R2445B
R9997 was R2473A
R9996 was R2487A
R9995 was R2641A
C9999 was C2349A
C9998 was C379A
C9997 was C386A
C9996 was C856A

Kicad does not allow refs like RxxxA some some devices have been renumbered
Extra PWR_FLAGS have been added to clear DRC errors
Some schematic symbols have been eeditd to clear DRC errors

Sheet: /
File: ebaz4205.kicad_sch
Title: EBAZ4205 Schematic rebuild.
Size: A3 Date: 2021-02-15 Rev: V004
KiCad E.D.A. kicad 5.99.0-unknown-d878cbddbc125ubuntu20.04.1 Id: /6